



PIONEER INTERTRADE

PRODUCT CATALOGUE

Sales & Service Locations in India



Head Office

301-303, "A" Wing, Durian Estate, Goregaon - Mulund Link Road, Goregaon (E), Mumbai - 400 063.
Phone : 022-6678 7700 / 6678 3162-63-64 • Fax : 022 - 6678 3161
e-mail : info@pioneerintertrade.com

We invite you to visit our website for complete information
including demonstration videos on various machines

www.pioneerintertrade.com

BASIC FEATURES

FEATURE	UNIT	VALUE
Grinder diameter	mm	400
Grinder thickness	mm	8/16
Motor power	Kw	9
Grinding wheel max. cutting speed	M/s	65
Roller diameter	mm	220
Tape width	mm	60
Tape development	mm	1450
Feeding stroke	mm	150
Transversal slide stroke	mm	100
Max. depth	mm	125*
Max. bevel depth "P"	mm	50
Noise level (work on thick ferrules)	Db	<85
Weight	Kg	175
Min. Diameter for internal work processes	mm	900

PATENT PENDING

- **light**
- **powerful**
- **compact**

USE

The G400 is a light, powerful, compact and versatile grinder suitable for rapidly carrying out the main process of tapping and grinding of ferrules and typical manufactured items for boilers.

Mounted on a medium-low range manipulator it can carry out internal and external work processes of:

- Longitudinal and circumferential back gouging.
- Chamfering of sheets with straight tack-welded edges.
- Removal of weld over-thickness by tapping.
- Smoothing of plating.

A special system of compensation means that this force can be maintained almost constant independently of the position taken by the slide during the work process (CONSTANT FORCE). The operating head can turn through 90° for circumferential and longitudinal grinding without having to move the manipulator arm.

ADVANTAGES

The time required for carrying out of welds with a manual grinder is considerably greater. With our machine, time is reduced by 1/3 to 1/5 in function of the type of work-pieces. The operator doesn't waste energy and works in completely safe conditions.

ACCESSORIES

Performance of the basic machine may be improved with the use of the following accessories:

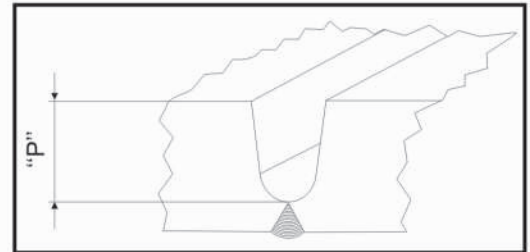
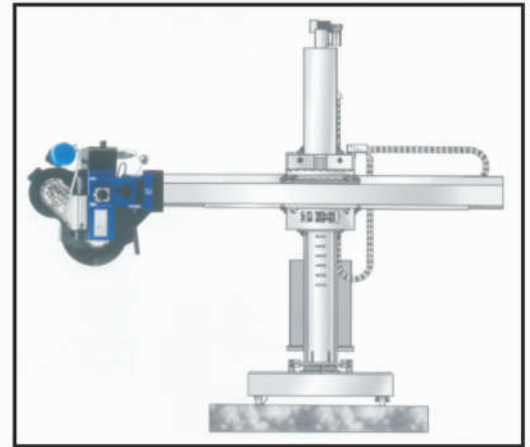

Gouging by grinder on cylindrical bodies

Circumferential external grinding from min. 500 mm

O.D. longitudinal grinding from min. 500 mm

I.D. longitudinal grinding from min. 2000 mm

The machine may be equipped with a trolley just for gauging of welding on circumferential bodies

The machine can be mounted on a manipulator (automatic welding type) in order to be used in both circumferential and longitudinal gauging

Mounted on the manipulator the machine can operate with grinder in vertical and/or horizontal position.

